

Impedance Analyzer

6632

Features

- Frequency range: DC, 10Hz to 1/3/5/10/20/30MHz/50MHz
- Basic accuracy up to $\pm 0.08\%$ (typical $\pm 0.05\%$)
- Automatic Level Control (ALC)
- Output impedance 25 Ω /100 Ω , switchable
- Using with DC bias current test system
- Support meter mode and list mode, sweep mode, and equivalent circuit analysis (option) function
- Built-in DC Bias voltage $\pm 12V$
- Measurement of piezoelectric element admittance circle, and can measure DC bias characteristic of capacitance value.
- Ultra-high measuring speed < 3ms
- Open circuit/short circuit/load correction function
- Up to four parameters can be selected in the electric meter mode. The inductance and DCR values can be measured and displayed simultaneously
- Auto component classification: Comparator function and Handler BIN classification function
- Can be used with various fixtures, such as: liquid dielectric material test fixture, dielectric material test fixture and magnetic material test fixture.....etc.
- Support RS-232, GPIB, Handler, LAN, USB Host/Device interfaces
- Using in R & D department, process development and laboratory
- PC connection data analysis software is available



CE RS-232 Handler USB Host/Device GPIB LAN

Applications

Passive Components: Capacitor, Inductor, Resistor, Transformer, Ceramic resonator, Quartz Crystal

Semiconductor Components: The CV characteristics analysis of varactor diodes, Diodes

Dielectric Material: Estimation on permittivity and consumption tangent of plastic, ceramic and PCB

Other Components: Estimation of the impedance of PCB components

Accessories/Fixtures

Standard Accessories

- Power Cord
- DIP Test Fixture (FX-000C19)



Optional Accessories

- PC Link software



- F423906A Kelvin Clip Leads (with BNC Box)



- F423503 DIP Test Fixture



- F423504 DIP Test Fixture



- FX-0000C6 DIP Test Fixture



- F423905 SMD Test Fixture



- FX-000C10 Bottom Electrode SMD Test Fixture



- FX-000C11 SMD Tweezer Test Leads



- FX-000C12 SMD Test Fixture



- FX-0000C7 Dielectric Material Test Fixture



- FX-0000C8 Magnetic Material Test Fixture



- FX-000C20 Liquid Dielectric Material Test Fixture



- F663001 A/B/C BNC Test Leads



- FX-0000C9 Material Testing Fixture



- F420001 External Voltage Bias ($\pm 200V/1MHz$)



- F420003 External Voltage Bias ($\pm 40V/1MHz$)



- F420005 External Voltage/Current Bias ($\pm 40V/100mA$)



- F420006 External Voltage Bias ($\pm 2000V/1MHz$)



- FX-LR0001 Automatic Level Compensation Fixture

Specifications ¹ S model is an optional equivalent circuit analysis function

Model Name	6632-1/1S	6632-3/3S	6632-5/5S	6632-10/10S	6632-20/20S	6632-30/30S	6632-50/50S
Test Frequency	10Hz-1MHz	10Hz-3MHz	10Hz-5MHz	10Hz-10MHz	10Hz-20MHz	10Hz-30MHz	10Hz-50MHz
Frequency Resolution	100mHz, 6 digits of setting						
Frequency Output Accuracy	±0.01%						
Basic Accuracy	±0.08% (typical ±0.05%)						
AC Drive Level	Voltage Minimum Resolution	1mV					
	Accuracy	ALC OFF: 10% of setting ±2mV ALC ON: 6% of setting ±2mV					
	Test Signal Current Level	200μA-20mArms					
	Current Minimum Resolution	10μA					
	Accuracy	ALC OFF: 10% of setting ±20μA ALC ON: 6% of setting ±20μA					
DC Drive Level	1V (fixed)						
Output Impedance	25Ω, 100Ω (switchable)						
Test Time (Fastest)	<3ms						
Measurement Parameters and Ranges	Z	0.000mΩ-9999.99MΩ					
	R, X	±0.000mΩ-9999.99MΩ					
	Y	0.00000μS-999.999kS					
	G, B	±0.00000μS-999.999kS					
	θRAD	±0.00000-3.14159					
	θDEG	±0.000° -180.000°					
	Cs, Cp	±0.00000pF-9999.99F					
	Ls, Lp	±0.00nH-9999.99kH					
	D	0.00000-9999.99					
	Q	0.00-9999.99					
	Δ	±0.00%-9999.99%					
	Rdc	0.00mΩ-99.9999MΩ					
	εr' εr''	0-100000					
	μr' μr''	0-100000					
Bias Current Source (option)	DC Bias 6243/ 6240(320A), 6223/ 6220(120A), 6210(60A)						

General

Measurement Mode	Meter mode, list mode, sweep mode	
Measurement Circuit	Series/Parallel	
Correction	Open Circuit/Short Circuit/Load correction	
Cable Compensation	0/ 0.5/ 1/ 2 m	
List Mode	50 groups of Multi-steps setting (Each group contains up to 15 steps)	
Built-in DC Bias	-12 to +12V, 0.3% ±1.5mV, 100Hz to 50MHz	
Bin sort	9 BINs	
Comparator	ABS, ΔABS, Δ%, OFF	
Built-in Storage	100 sets LCR setting documents, 50 groups of list mode setting	
USB Host Storage	LCR setting documents, list mode setting document, BMP graphics, Sweep screen and test result data	
Trigger Test	Auto, manual, RS-232, GPIB, Handler	
Interface	RS-232, GPIB, Handler, LAN, USB Host/Device	
Option	PC link software	
	Equivalent Circuit Analysis	Three elements (4 models), four elements (3 models)
Power Supply	Voltage 100-240Vac	
	Frequency 50-60Hz	
	Low power consumption: Maximum 30W	
Display	7.0" TFT, 800×480 color screen	
Environment	Temperature: 10-40°C, Humidity: 20-80%RH	
Dimension (W*H*D)	336×147×340mm	
Weight	3.95kg	

6632 Key Features

A Function Introduction

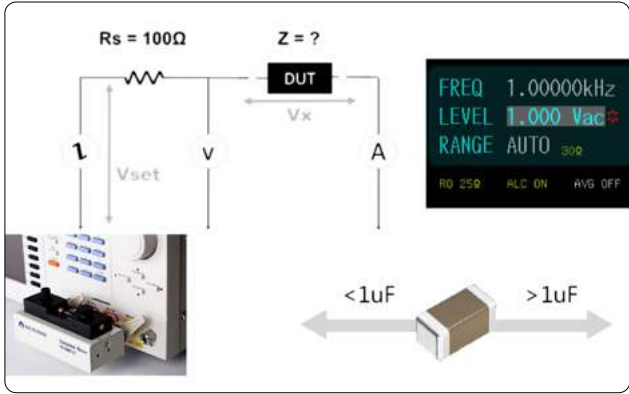

Output Impedance 25Ω/100Ω and Auto Level Control (ALC)

The key parameters for capacitance are Cs/Cp/D/Q/ESR/DC Bias Voltage.

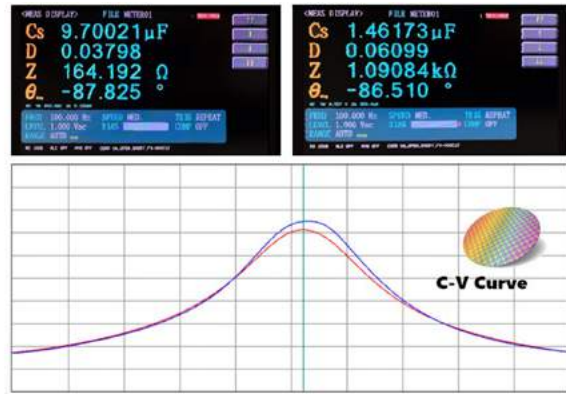

Evaluation of DC bias voltage characteristics with semiconductor wafer or ceramic multilayer capacitors

Multi-layer ceramic capacitors (MLCC) DC Bias measuring value from 9.7uF decrease to 1.46uF.



Liquid Dielectric Material Test Fixture (C20) /Dielectric Material Test Fixture (C7)

Using C20 for measuring the characteristics of electrochemical materials and using C7 or measuring PCB board or ceramic board.



Magnetic Material Test Fixture (FX-000C8)

Using the magnetic material test fixture for measuring of permeability of various toroidal cores or ferrite cores and electromagnetic shielding coating materials, 6630 built-in formula to directly calculate the permeability coefficient value μ' , μ'' .

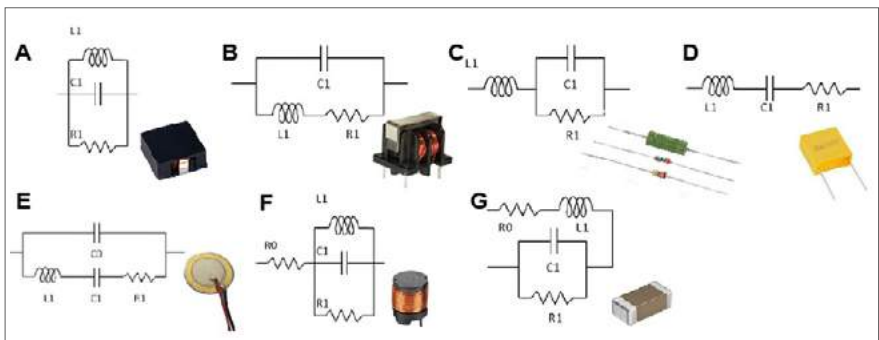
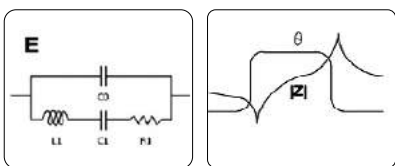

Equivalent Circuit Analysis

It has seven different models, combine with different types of parameters (R, L, C), you can see three or four elements value, and self-resonant frequency (SRF). You can simulate the impedance trace of your own equivalent circuit parameter values and then compare it with an accrual measurement trace.

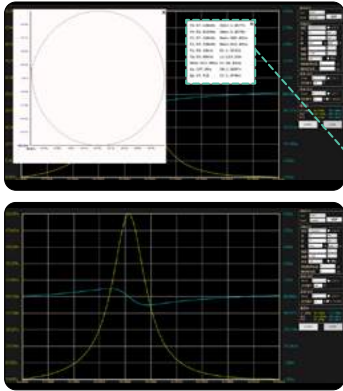

Fm:57.430kHz **Zmin:1.0377k**
Fn:59.815kHz **Zmax:2.0376k**
F1:57.160kHz **Bmax:905.052u**
F2:59.320kHz **Bmin:432.842u**
Fs:58.18kHz **R1:1.9132k**
Fp:59.08kHz **L1:133.55m**
Gmax:521.994u **C1:56.034p**
Kp:197.05m **C0:1.8687n**
Qm:25.518 **Ct:1.9796n**

Piezoelectric element/quartz crystal analysis frequency characteristics

The key parameters for Piezoelectric element /quartz crystal are $F_s/F_p/Q_m/K_p$ (Electromechanical coupling coefficient)



Evaluation impedance characteristics of RFID/ NFC/automotive wireless of antennas

Using 6632 impedance analyzer equivalent circuit Analysis function.



Testing PC board inductance coil

The key parameters for 6632 impedance analyzer measuring PC board inductance coil are $L/Q/DCR/R_s/SRF$.

B Applications

Passive Component



inductance
 $L_s/L_p/Q/SRF/I_{sat}/I_{rms}$

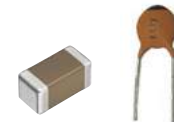

MLCC/capacitance
 $C_s/C_p/D/Q/ESR/DC\ Bias\ Voltage$

Acoustic Components



Voice coil motor/Hearing aids
 $L_s/Q/Q_m/SRF$

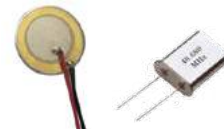

Piezoelectric element /quartz crystal
 $C_s/C_p/D/F_s/F_p$

Material



Magnetic material
 $\mu_r'' \mu_r'$



Dielectric/ceramics/ Electrochemical materials
 $\epsilon_r' \epsilon_r''$

Wireless RF/Power Supply



Wireless charging
 $L_s/Q/SRF/DCR/R_s$



NFC/low Freq. RFID
 $L_s/Q/SRF/DCR/R_s$



battery
 $ESR/C_s/C_p/D$

Semiconductor Components



Wafer
C-V



LED Light board
 $Z/C_s/C_p/D$



diode
 $C_s/C_p/D$